

Every 3 months or after 1000 operating hours

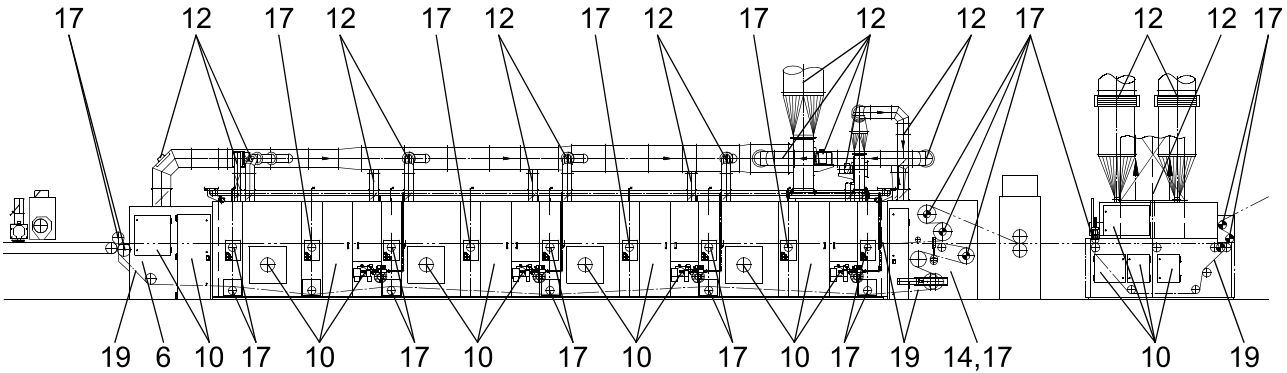

No.	Where?	What?	How?	ok
1 - 20	Complete machine	Gas pipes	<p>Check the tightness of the gas line (complete annular piping).</p> <p>Clean filters in front of gas burners, clean (blow out) filter and gas pipes in case of soiling.</p>	
17	Complete machine	All roller bearings	<p>Lubrication of each bearing with 3 cm³ of “SETRAL SYN-setral-INT/250 A-1” (BRÜCKNER code 72432-984):</p> <ul style="list-style-type: none"> • up to 200 °C: every 2000 operating hours • up to 215 °C: every 1000 operating hours 	